

doi:10.15199/48.2016.02.37

The model of a vacuum circuit breaker in MATLAB software for the analysis of overvoltages and overcurrents in capacitive electrical circuits

Streszczenie. Praca przedstawia metodę modelowania łącznika próżniowego w programie MATLAB/SIMULINK oraz wyniki i analizy przebiegów oraz prądów otrzymane podczas symulacji operacji łączeniowych w obwodzie pojemnościowym.

Abstract. The paper presents the method of modelling a vacuum circuit breaker in MATLAB/SIMULINK software and also the results of verification of its operation and practical usefulness for conducting analysis of overvoltages and overcurrents occurring in commutated capacitive electrical circuits. Examples of digital simulations of overvoltages and overcurrents in selected electrical circuits are also provided and the optimal conditions for the switching off of capacitor banks are determined. (Model łącznika próżniowego w programie MATLAB oraz analiza przebiegów i prądów w obwodzie pojemnościowym).

Słowa kluczowe: symulacja, łącznik próżniowy, matlab,
Keywords: simulation, vacuum switch, matlab.

The Model of a vacuum circuit breaker in MATLAB software

The presented model of a vacuum circuit breaker (Fig. 1) was programmed in the Matlab/Simulink environment which is compatible with version R210b [1]. In this environment there is a possibility of creating a model with a graphical user interface (Simulink), which makes it simple to use and easy to modify. The determined model is a model of a three-phase circuit breaker. However, in order to make it easier to understand its operation and to simplify its description the article presents a model of a single-phase circuit breaker. Models of each current circuit of the three-phase circuit breaker are similar and were placed in each circuit considering the phase shift of currents and voltages

The model of a single-phase vacuum circuit breaker consists of two parts: a Matlab/Simulink "ideal switch" block (switch_L1, Fig. 1) which was taken from the software library and also an "ideal switch" control block (control_L1, Fig.1 and Fig. 2) which controls the operation of the model. This control is based on the measurement of voltage and current at the "ideal switch" contacts (L1_in).

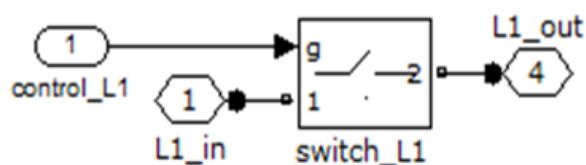

Fig. 1. The model of a vacuum circuit breaker in Matlab software: control_1 - control block, L1_in – input signal, L1_out – output signal

In the control block the following conditions are verified (Fig. 2):

1. Permissible return voltage value U_w which was determined according to formula [2]:

$$(1) \quad U_w = A_1 \cdot b^d$$

where: A_1 , b – are coefficients which depend on the contact material, d – is the gap between contacts [mm].

2. The value of the chopping current (which is introduced in the additional panel - Fig. 7).

3. The maximal slope of the current increase - 150 A/ μ s.

In order to reflect real phenomena during the various operating states of a circuit breaker, a bistable circuit breaker was used in the model. At the input gate [S] the given signal initiates the contact closure. When its value exceeds the permissible value of the return voltage, the closure of "ideal switch" contacts occurs (re-ignition in a vacuum circuit breaker). Whereas on the R input, the given signal initiates the disconnection of "ideal switch" contacts after checking the current conditions listed above.

The first switching off is accomplished by a unit spike given at the [S] input, which causes the switching off of the current when it first passes through zero.

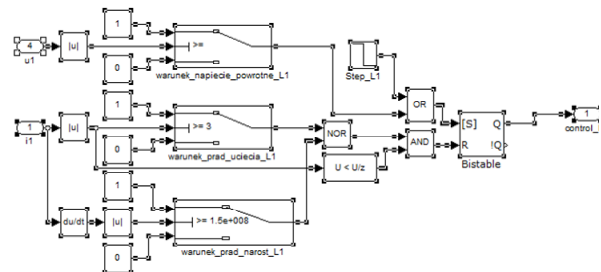

Fig. 2. Control block scheme of the vacuum circuit breaker in Matlab software

The model enables the operation of the real vacuum circuit breaker to be imitated. Simulation of transient phenomena during the switching off of a capacitive circuit with the use of a vacuum circuit breaker begins from the controlled switching off after which, depending on the value of return voltage, re-ignition of the arc either occurs or not. The phenomenon of the correct switching off repeats until the obtained value of the chopping current and the slope of the increase of high-frequency currents will permit the permanent switching off (conditions are given above). Simulation may end up with the result of the lack of the correct switching off if conditions for the correct switching off will not be obtained within a specified time of the simulation

Model of the capacitive circuit commutated with the vacuum circuit breaker

Simulations of transient waveforms of currents and voltages occurring during the switching off of electrical

capacitive circuits including - presented in the article - waveforms occurring during the switching off of a three-phase capacitor bank with an insulated and also grounded neutral point (Fig. 3), were carried out with the use of the developed model of a three-phase vacuum circuit breaker and the model of a capacitive circuit created in Matlab software (Fig. 5). Simulations were conducted for the conditions of supplying a commutated circuit with medium voltage (6-15 kV) and various values of parameters of a capacitor bank and also various values of RLC parameters of the power supply circuit (Fig.4) which were taken from catalogues of capacitors and power cables [3]. Intuitive additional panels, which guide the user step by step from the implementation of data required in a simulation to the procurement of results (Fig. 6 and 7), were created for the purpose of quick data implementation and to ensure the possibility of analysis of the obtained results.

a)

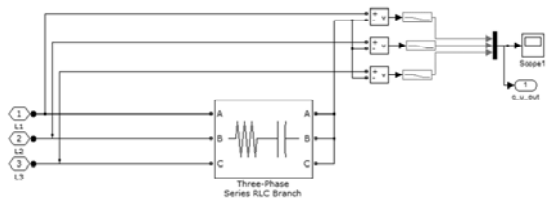

b)

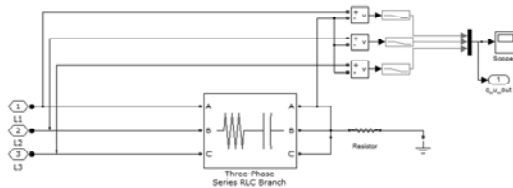

Fig. 3. Matlab software model of capacitor banks with an isolated (a) and grounded (b) neutral point created for the simulation of transient waveforms of currents and voltages which occur during the switching off of capacitor banks with a vacuum circuit breaker

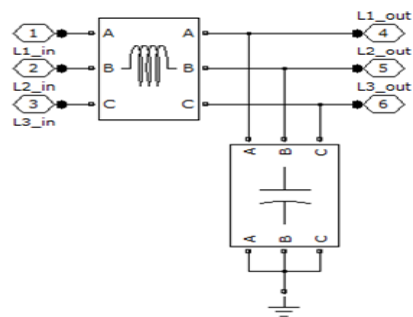

Fig. 4. RLC parameters of the power supply circuit in the model of a capacitive circuit

After starting the simulation, the program enables parameters to be selected by a user entering them in the additional panel (Fig.7) or by using a file which was previously created in the program for this purpose. Then the simulation starts and after the calculations are accomplished the program provides a message stating its completion. There is an option to display the obtained results and characteristics in one additional window, such as: voltage and current waveforms from the circuit and overvoltage values calculated for each of the phases (Fig. 8).

Apart from the values checked in the control block of the circuit breaker model (value of chopping current, slope of the increase of high-frequency current, gap between contacts) and circuit parameters (capacitor bank power, voltage supply), the time of opening the contacts of the vacuum circuit breaker and also the delay in the opening of the circuit breaker can be introduced to the additional panel (Fig. 7). This allows the phenomenon of non-simultaneous opening of contacts of the three-phase circuit breaker to be analysed

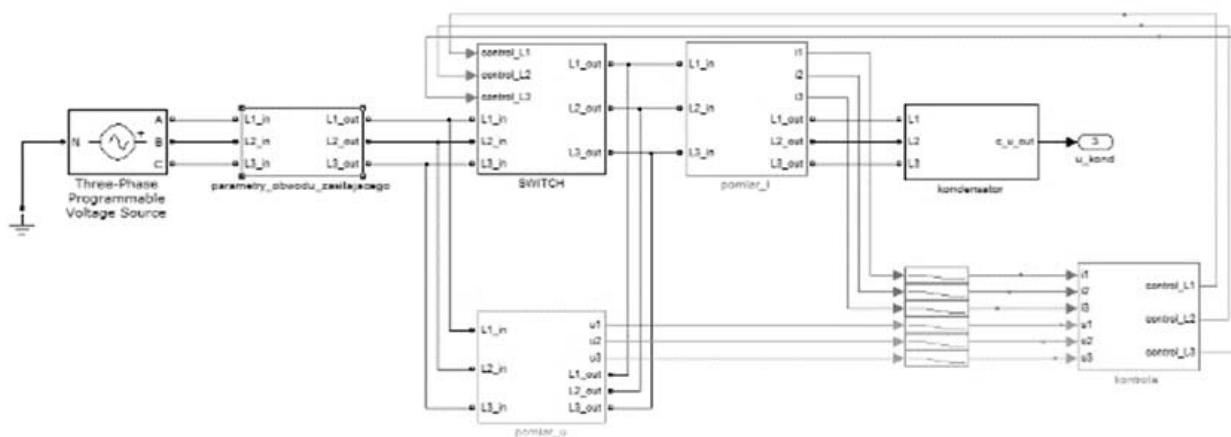

Fig. 5. Model of a capacitive circuit in Matlab software

The model also provides additional information regarding the waveforms and values at various stages of the simulation. This enables a graphical model of a commutated circuit in which are placed meters (scope) that permit a wider look of the circuit to be created in Simulink.

This information is not displayed in dialog windows but is available straight after the end of the simulation

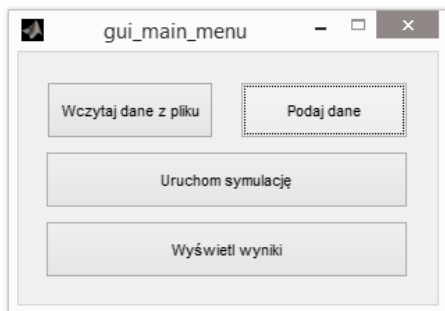

Fig. 6. Main menu of the software

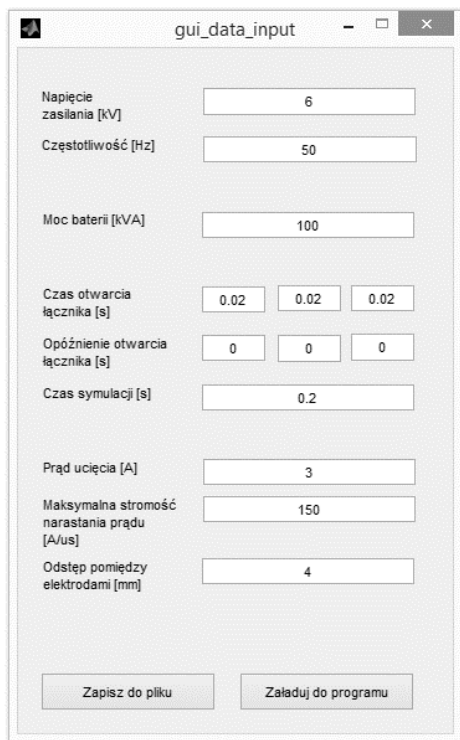

Fig. 7. Additional panel which enables the parameters required in a simulation to be implemented

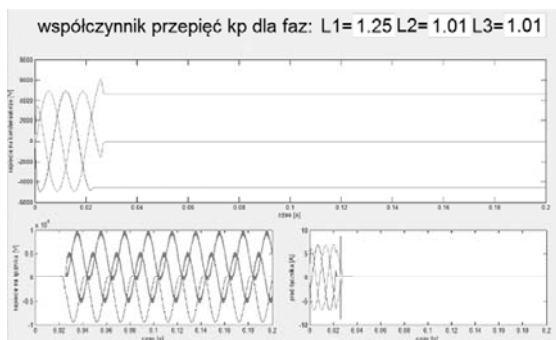

Fig. 8. Window with exemplary simulation results

Results

Many simulations of transient waveforms of currents and voltages occurring during the switching off of capacitor banks with the vacuum circuit breaker were carried out in order to verify the correctness and practical usefulness of the developed model. Research referred to the designation of dependencies between observed waveforms and

changes of vacuum circuit breaker parameters (chopping current $I_u = 1 - 4$ A, contact gap length equal to $d = 1$ until 4mm, delays in opening of contacts in the specified current circuits $s = 0$ to 0.06s), capacitor bank parameters (capacitor bank power equal to: 100 up to 500 kVAr, the way of connecting the neutral point of the capacitor bank with the ground: insulated or grounded) and also the changes in the values of the voltage of the circuit supply ($U_n = 6 - 15$ kV). The results of the carried out simulations illustrate waveforms which are shown in examples in Figures 10 to 15.

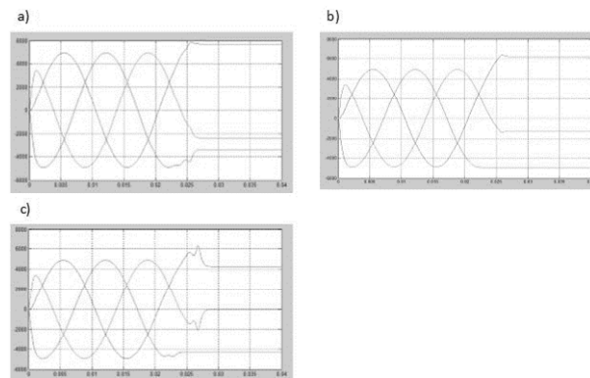

Fig.9 Voltage waveforms at the clamps of capacitor banks at various chopping current values and different lengths of a vacuum circuit breaker contact gap: a). $I_u = 2$ A, $d = 3$ mm, b). 3 A, $d = 4$ mm, c). 4 A, $d = 4$ mm

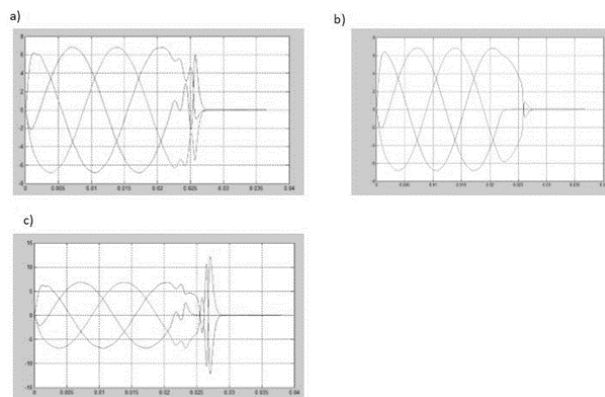

Fig. 10. Waveforms of currents in a vacuum circuit breaker (a), voltages at clamps of capacitor banks (b) and voltages at contacts of a circuit breaker (c) during the switching off of a commutated circuit at $I_u = 3$ A, $d = 4$ mm, $Q = 500$ kVAr, $U = 15$ kV where U – is the supply voltage, I_u – is the chopping current, d – the contact gap distance and Q – is the capacitor bank power

The analysis of conducted simulations leads to the following statements:

- dangerous overvoltages appear in the model with an insulated neutral point of capacitor banks (see Fig.3a)
- the model with a grounded neutral point of capacitor banks (Fig. 3b) can be analysed as a single-phase circuit due to the fact that the switching off in the individual phases occurs analogously. The exception is a variant of examining the impact of the phenomenon of delay in the disconnection of contacts in the specified phases of the vacuum circuit breaker and in such a case waveforms of voltages and currents in all phases undergo analysis (Fig.10).
- with voltages between 6 and 15kV, safe conditions were achieved with $I_u = 3$ A and $d = 4$ mm (Fig. 9.)
- dangerous values of the overvoltage coefficient with values between 1.4 and 2.5 were obtained in the circuit

where the value of supply voltage was equal to 15kV, $I_u = 3A$, $d = 4mm$ and the maximal considered delay in disconnection of contacts was equal to 0.06 between L1 and L3 (Fig. 11)

- the occurrence of overvoltages can be prevented by grounding the neutral point of capacitor banks (Fig. 12).
- the application of grounding by a resistance greater than 5 Ω cancels unwanted current peaks which occur during transient phenomena when switching off the circuit .

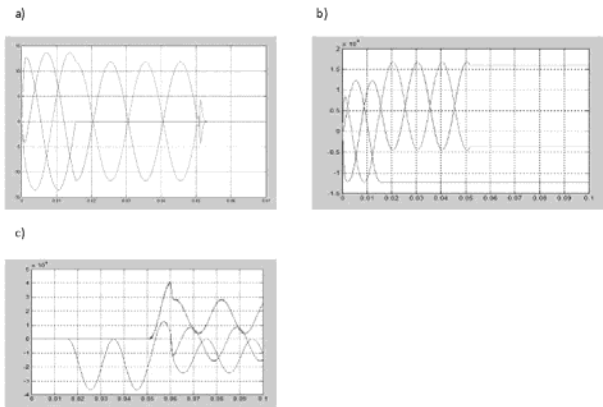

Fig. 11. Waveforms of currents in a vacuum circuit breaker (a), voltages at clamps of capacitor banks (b) and voltages at contacts of a circuit breaker (c) during the switching off of a commutated circuit at $I_u = 3 A$, $d = 4 mm$, $Q = 500kVAR$, $U = 15 kV$ and with a delay in opening of contacts in specified current circuits of a circuit breaker equal to: $L1 = 0$, $L2 = 0.01 sec.$, $L3 = 0.06 s$

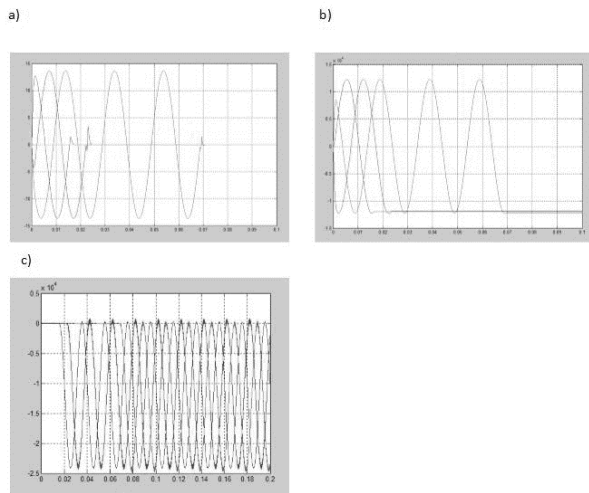

Fig. 12. Waveforms of currents in a vacuum circuit breaker (a), voltages at clamps of capacitor banks with a grounded neutral point (b) and voltages at contacts of a circuit breaker (c) during the switching off of a commutated circuit at $I_u = 3 A$, $d = 4 mm$, $Q = 500kVAR$, $U = 15 kV$ and with a delay in opening of contacts in specified current circuits of a circuit breaker equal to: $L1 = 0$, $L2 = 0,01s.$, $L3 = 0.06s$

Conclusion

The presented model of the digital vacuum circuit breaker and the commutated electrical capacitive circuit which was modelled in Matlab/Simulink software enables multi-criteria analysis of transient waveforms of currents and voltages which occur during the switching off of capacitive circuits, especially capacitor banks operating with an insulated or grounded neutral point, to be carried out. The developed model is easy to use and very functional due to the application of intuitive additional panels and the display of results in a single window. It can be useful at the design stage, during the creation of new capacitive circuits, as well as at the stage of modernization and operation of such circuits.

The verification showed large, sufficient enough for practical estimations, compatibility of results of simulations carried out with the use of this model with the results of empirical studies presented in the subject literature [4, 5] which proves the correctness of the developed model and its practical usefulness.

The developed model is a practical and effective research tool which, thanks to its advantages and possibilities, reduces the time of multi-criteria analyses regarding phenomena occurring during the switching off of capacitive circuits with vacuum circuit breakers.

Autors: *prof. dr hab. inż. Zbigniew Wróblewski, Politechnika Wroclawska Katedra Energoelektryki, ul. Janiszewskiego 8, 50-372 Wrocław, E-mail: zbigniew.wroblewski@pwr.edu.pl; dr inż. Joanna Budzisz, Politechnika Wroclawska Katedra Energoelektryki, ul. Janiszewskiego 8, 50-372 Wrocław, E-mail: joanna.budzisz@pwr.edu.pl;*

REFERENCES

- [1] Matlab support, www.mathworks.com.
- [2] Budzisz J., Wróblewski Z., Modeling of switching effects in capacitive circuit with a vacuum switch and varistor surge protection. *Przeгляд Elektrotechniczny*. 2012, R. 88, no 5a, p. 284-289.
- [3] Solidna energia, Kable i przewody elektroenergetyczne. Katalog Telefoniki <http://www.tfkable.com/>, Kable elektroenergetyczne o izolacji z polietylenu usieciowanego na napięcie: 3.6/6 kV, 6/10 kV, 8.7/15 kV, 12/20 kV, 18/30 kV.
- [4] Wróblewski Z., Research and digital simulation of selected properties of vacuum circuit breakers, Wrocław University of Technology Press, Wrocław 2005.
- [5] Karolak J., Processes when connecting capacitor banks with vacuum circuit breakers. Instytut Energetyki, Warsaw 2001, PhD Dissertation.