

doi:10.15199/48.2022.11.12

An Efficient Approach for Optimization Of The Parameters In Transmission System Applied In DWT+SPIHT Using Whale Algorithm (WA)

Abstract. The compression of image using analyzing techniques give us a high quality in the reconstructed image however in the case of transmission produce a sensitive (to the channel noise) image. In this paper we are going to use combination between error detection, source and channel coding with unequal distribution in the code rate our approach shows a high efficiency and optimization in the use of the code rate using Whale Algorithm (WA) (minimization in the redundant bits) compared to other approaches. The results of the work carried out in this article are mainly focused on the medical images compression by the (DWT+SPIHT) method, which, in fact, allow a significant reduction for data. We are also interested in the transmission of these images on an channel in a way that can provide a high bit rate with good transmission quality, by exploiting the channel coding technique, which is effective in combating the noise introduced during the transmission of these images

Streszczenie. Kompresja obrazu przy użyciu technik analitycznych daje nam a wysoką jakość rekonstruowanego obrazu, jednak w przypadku transmisji wytwarzamy obraz wrażliwy (na szum kanału). przy nierównym rozkładzie współczynnika kodowania nasze podejście wykazuje wysoką wydajność i optymalizację w wykorzystaniu współczynnika kodowania przy użyciu algorytmu wieloryba (WA) (minimalizacja w nadmiarowych bitach) w porównaniu z innymi podejściami. Wyniki prac przeprowadzonych w niniejszym artykule koncentrują się głównie na kompresji obrazów medycznych metodą (DWT+SPIHT), która w rzeczywistości pozwala na znaczną redukcję danych. Interesuje nas również transmisja tych obrazów na kanale w sposób, który może zapewnić wysoką przepływność przy dobrej jakości transmisji, wykorzystując technikę kodowania kanałów, która skutecznie zwalcza szumy wprowadzane podczas transmisji tych obrazów. (Efektywne podejście do optymalizacji parametrów w systemie przesyłowym stosowane w DWT+SPIHT z wykorzystaniem algorytmu wielorybów (WA))

Keywords: CRC code, DWT, SPIHT, RS code, UEP, BSC,WA. medical images compression, transmission, channel coding

Słowa kluczowe: obrazowanie medyczne, kompresja obrazu, przesyłanie obrazu

Introduction

The specific choice of transformation type, quantization and entropy coding leads to a wide coder's variety. Numerous compression schemes have been proposed and standardized: for example, conventional compression algorithms, more sophisticated methods have been defined. several compression algorithms have been developed such as "Set Partitioning In Hierarchical Trees" (SPIHT) [1], this algorithm makes it possible to progressively transmit images. We will, in what follows, present the principle of this progressive transmission.

Wavelet Transform (WT) has received more and more significant attention in signal compression. However, many differences lie in the performance of different wavelets. There is a need to select the optimal matched wavelet bases to analyse the signal and the signal needs to be expressed with the fewest coefficients, i.e. sparse coefficients [2].

We will then propose the unequal protection application of the bit stream with Optimization of the bit rate allocation between source coding and channel coding. Two optimization criteria will be presented: Quadratic Mean Error (MSE), peak signal-to-noise ratio (PSNR). The developed optimization method will be applied to the DWT+SPIHT encoder for source image compression

The use of optimization techniques takes lot of attention in many applications to solve research problems [1]. In case of transmission using channel coding techniques there is no guarantee that makes us sure about the selected parameters if they are adaptive to the channel noise, which make us confused about the technique that can be used to select the parameters. The use of RS code need to determine the code rate value according to the channel conditions with minimum redundancy bits. To achieve this aim we are going to use Whale Algorithm to define the input

parameter of the RS code with specific conditions to find the global optimum code rate.

Images progressive transmission

Let's start by introducing some definitions relating to the images progressive transmission [3]. A bit frame at the image encoder output is said to be progressive if it can be decoded at different compression ratios, resulting in an improvement in the obtained image quality, as bits are added additionally. A binary frame is said embedded in a second binary frame if it is a prefix of the latter. An image encoder is said to be progressive if it produces, for each transmission rate, a progressive bit frame. Images encoding is called embedded coding if the produced frame for a given bit rate is nested in the produced frame for any other higher value bit rate. It is clear that a nested images encoding is necessarily progressive. (Fig. 1) illustrates the concept of progressivity by showing a series of decoded images from the same bit frame at increasing rates ranging from 0.01 bpp to 0.2 bpp. It is obvious that higher is the bit rate, better is the visual quality of the rendered image.

In what follows, we will develop more explicitly the progressivity aspect in an image transmission [1] [4] [5]. To do this, let us begin by reminding ourselves that the main objective of a progressive transmission scheme is to transmit first the information generating the greatest reduction in distortion. Let us note the pixels set of the original image where i and j denote the pixel coordinates, and the used transformation. The transformed image is:

$$(1) \quad Y = T(x)$$

The matrix Y has the same dimensions as the matrix X representing the source image. Each element is called coefficient of the transform at coordinates (i, j) . The coding algorithm applies directly to the transformed image Y .





	
CR=0.01 bpp. PSNR = 22.45 dB	CR= 0.02 bpp PSNR = 24.3
	
CR=0.1 bpp. PSNR = 29.99 dB	CR= 0.2 bpp PSNR = 32.98 dB

Fig.1. Illustration the concept of progressivity coding of the (medical image) 512 × 512 image using SPIHT algorithm.

In the progressive transmission case, the decoder starts by initializing the reconstruction matrix to zero. Then, it updates the matrix components according to the decoded message. As it determines the values (exact or approximate) of certain coefficients, the decoder is able to obtain a reconstructed image:

$$(2) \quad \hat{x} = \tau^{-1}(\hat{Y})$$

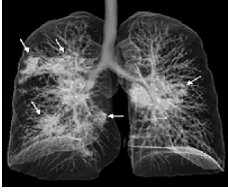
Using the mean squared error (MSE) as a distortion measurement, we have

$$(3) \quad D_{MSE}(X, \hat{X}) = \frac{1}{N} \sum_i \sum_j (x_{i,j} - \hat{x}_{i,j})^2$$

where N is the pixels number in the image. Assuming that the transformation preserves the Euclidean distance, we can write:

$$(4) \quad D_{MSE}(X, \hat{X}) = D_{MSE}(Y, \hat{Y}) = \frac{1}{N} \sum_i \sum_j (y_{i,j} - \hat{y}_{i,j})^2$$

Thus, the exact restitution of a transform coefficient leads to the MSE reduction of . As a result, in a progressive transmission scheme, the higher amplitude coefficients must be transmitted first because they generate the greatest decreases in distortion. In the same spirit, the contained information in the amplitude of a coefficient can be distributed between the different bits constituting the binary representation of and varies according to the nature of these bits. Indeed, the most significant bits (MSBs) provide more information on the coefficient value than the other bits. They must therefore be transmitted first. This is the principle used in bitmap coding techniques for progressive transmission.

Wavelet Transform

We can adapt wavelet transform in case of a discrete set. Such a technique is especially used with digital data with or without loss. Compression is achieved through successive approximations of initial information from the roughest to the finest. Therefore, we reduce information size by choosing a detail level [6].

Hence, we make a sampling of s and on a dyadic scale. We have then:

$$(5) \quad \psi_{m,n}[t] = S_0^{-\frac{m}{2}} \psi(S_0^{-m} t - n \tau_0)$$

Where and are constants .

We define discrete wavelet transform as follows:

$$(6) \quad g[t] = \sum_{m \in Z} \sum_{n \in Z} \langle X, \psi_{m,n} \rangle \psi_{m,n}[t]$$

SPIHT Algorithm

The SPIHT algorithm [1] takes the principles mentioned in EZW [2] while proposing to recursively partition the coefficient trees (Fig. 2). Thus, where EZW coded an isolated insignificant coefficient ('Z'), SPIHT performs a recursive partitioning of the tree in order to determine the significant coefficients position in the progeny of the considered coefficient. The significant coefficients are coded in a similar way to EZW: their sign is sent as soon as they are identified as significant and they are added to the coefficients list to be refined. This algorithm also works by bit planes [7]. It offers remarkable performances, reaching those of EZW without entropy coding. Adding entropy coding of the significance information, an additional gain between 0.3 and 0.6 dB is obtained. The bits sent during the significance pass correspond to the program executed at the encoder during the execution of the classification algorithm into significant and insignificant coefficients. By following the same program, the decoder remains synchronous with the decisions of the encoder and finds the same classification [8]. This algorithm is based on the management of three lists, significant coefficients (LSP), insignificant coefficients (LIP) and insignificant sets (LIS). With a significance threshold divided by two at each iterations, and whose initial value is transmitted to the decoder, the algorithm proceeds as follows [9].

The significant coefficients list is initially empty, while the insignificant coefficients list contains the roots of each tree (coefficients of the low band) and the descendants of each tree. This initial partition is segmented recursively by means of two rules. If a set of descendants of a node is significant, it is separated into four direct child coefficients of this node, and all the other descendants.

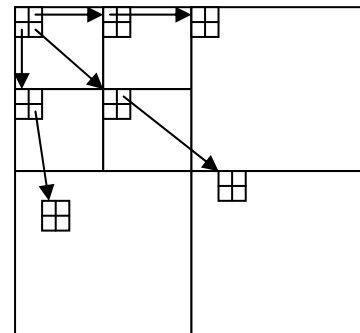

Fig.2. Tree structure of wavelet coefficients in the case of SPIHT

Direct threads are added to the LIP or LSP according to their significance. If at least one element of all other descendants is significant, this set is separated into four insignificant sets added to the LIS. Processing the coefficients in groups of four allows efficient entropy coding thereafter. As in EZW, the refinement pass consists of progressively coding the least significant bits of the significant coefficients.

When the complexity increase due to the entropy coder use is not limiting, contextual adaptive arithmetic coding of the significance bits is possible to improve the compression performance. The coefficients being coded in four groups, it is interesting to treat them globally to exploit an entropy of

order greater than 1. The coefficients can only pass from the insignificant state to the signifying state, the size of the necessary alphabet to represent these changes varies according to the number of coefficients already signifying in the group.

Thus, it is proposed in [1] to use four contexts as a function of the insignificant coefficients number varying from 1 to 4, respectively conditioning a law on an alphabet of 2 to 16 symbols. The sign bits as well as the refinement bits are not compressed, their entropy being already close to 1.

Whale Optimization

The WOA (Whale Optimization Algorithm) is a novel nature-inspired meta-heuristic optimization algorithm, which mimics the social behavior of humpback whales. The algorithm is inspired by the bubble-net hunting strategy [10-11].

In the bubble-net hunting technique, the humpback whales dive approximately 12 meters down and then begin to make bubbles in a spiral shape around the prey and swim toward the surface [12-13].

The Whale Optimization Algorithm is very competitive compared to the state-of-art meta-heuristic algorithms as well as conventional methods [10-14].

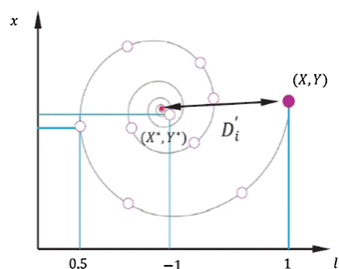

Fig.3. Spiral updating position

Optimization for channels without memory

In image transmission systems designing, there is often a major problem of ensuring high robustness against transmission errors while maintaining a high spectral efficiency of the system. This results in a compromise made in the system parameters choice between a very strong compression resulting in a low bit rate at the output of the source code and a very strong protection against errors obtained by low yield channel coding means. In the channel without memory case, it is assumed that the average error rate on the channel as well as its bandwidth will impose a maximum transmission rate. Knowing the maximum number of bits allowed per image, it is important to carefully choose the source encoder compression rate and the channel encoder output in order to have a reconstructed image with the best possible quality. It should be noted that reducing the channel coding efficiency, of course, gives better protection against errors, but the overall transmission rate being fixed, it is then necessary to increase the compression at the level of the source coding which results in a PSNR decrease in the first time with errors absence. Therefore, the channel coding efficiency adjustment must be done in such a way as to avoid wasting bits creating unnecessary redundancy, preserving a sufficiently low error probability after decoding. The problem is to find an optimal bit rate allocation between the source coding and the channel coding for a given transmission channel.

Performance RS code

The different encoder performance is represented: the bit error rate as a function of the channel error probability, in Fig.3.

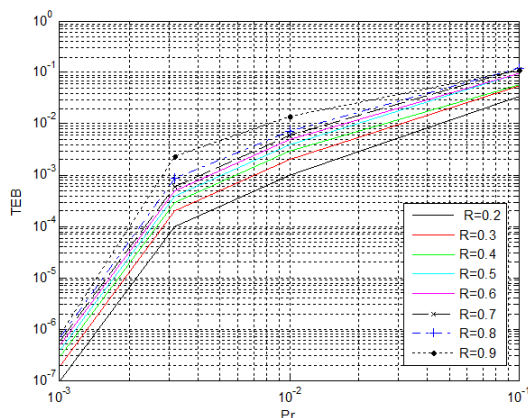

Fig. 4.error Bit rate in function of error probability.

Protection of DWT+SPIHT encoded images by reed solomon code (RS)

Description of the coding scheme

In what follows, we propose the reed solomon (RS) code application for the protection of images coded by the DWT+SPIHT algorithm (with arithmetic coding). The block diagram of the transmission chain under consideration is shown in Fig.5.

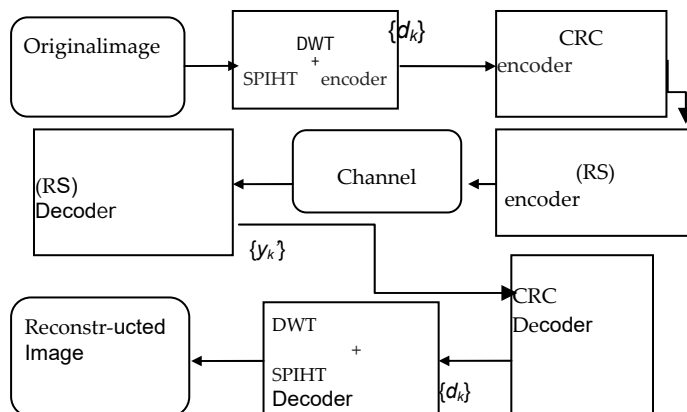

Fig.4. Block diagram of the transmission

The data delivered by the DWT+SPIHT encoder is partitioned into consecutive blocks of size (R_i-16) bits each. It is assumed that the channel coding strategy is done in two steps: error-detecting coding (CRC) followed by error-correcting coding (reed Solomon RS). The role of error detection is to interrupt the decoding of the first detected error and therefore to reject the bits that can contribute to the propagation of errors. At the receiver, the decoding is stopped at the first detected erroneous packet, since the following packets are generally unable to improve the quality of the decoded picture. The CRC encoder adds 16 redundancy bits to each block.

The resulting data is transmitted on a channel without memory. At the receiver, a decoding (RS) is performed at the output of the channel (in the case of a symmetrical binary channel). The use of these codes makes it possible to have very high coding efficiencies giving rise to a better spectral efficiency of the system.

Choice of coding performance and results on a BSC

In what follows, we will discuss the problem of adjusting the channel coding efficiency for a given transmission channel error probability. For this, we consider a set of Code Rates obtained for EEP and UEP protection:

{0.2, 0.3, 0.4, 0.5, 0.6, 0.7, 0.8, 0.9}. The manual UEP protection system is tested with RS on "medical image". A Symmetric Binary Channel (BSC) with two BERs: , and is considered. The selection of the reed solomon (RS) code to be applied for each BER of the channel is done experimentally. Indeed, the code (RS) is applied to obtain the highest efficiency, a global bit rate (including source coding and channel coding) of 0.25 to show the (RS) used. In Fig. 5 we provided some results of decoded images with EEP and UEP protection, in order to illustrate the improvement brought by the application of RS at the visual quality level of the images transmitted on a Symmetric binary error rate channel 10^{-2} , or 10^{-3} .





	
Original image (medical image)	DWT+SPIHT TEB=0, PSNR=34.1187dB
	
DWT+SPIHT +RS (EEP) TEB=10-2, PSNR=30.43 dB	DWT+SPIHT +RS (UEP) TEB=10-2, PSNR=31.65dB
	
DWT+SPIHT +RS (EEP) TEB=10-3, PSNR=33.87dB	DWT+SPIHT +RS (UEP) TEB=10-3, PSNR=34.10dB

Fig.5. Recieved medical image with EEP and UEP protection transmitted in BSC channel (CR = 0.25 bpp).

Joint optimization of bit rate allocation between source coding and channel coding

This first study allowed us to highlight the efficiency of a channel coding scheme, using the reed solomon (RS) code, for the protection of DWT+SPIHT coded images transmitted over a symmetric binary channel. In what follows, we will study in more detail the problem of joint optimization of the rate allocation between a nested source encoder and any channel encoder.

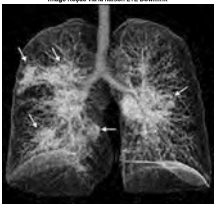
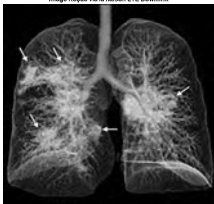
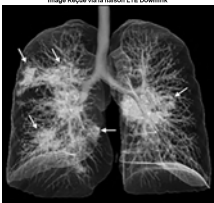
Coding and transmission process

We are interested in encoding and transmitting, on a noisy channel without a given memory, a bit frame delivered by a nested source encoder, coding an HS number of source symbols. It is assumed that the channel coding strategy is done in two steps: error-detection coding followed by error-correcting coding. The role of error detection is to interrupt the decoding of the first detected error and therefore to reject the bits that can contribute to the propagation of errors.

We suppose that we have a set:

$$(7) \quad C = \{c_1(N_{c1}, K_{c1}), c_2(N_{c2}, K_{c2}), \dots, c_L(N_{cL}, K_{cL})\}$$

Of errors correction codes. The compressed bit frame is formatted into packets of variable length. Each packet of length K_{cl} bits is encoded by a code to generate a coded packet of length N_{cl} bits. We introduce, for each , the following ratios, expressed in bits per symbol of the source:

$$(8) \quad r_m(c_1) = \frac{K_{cl}}{H_s} (bpp) \text{ et } r_c(c_1) = \frac{N_{cl}}{H_s} (bpp)$$

At the receiver, the decoding is stopped at the first detected erroneous packet, since the following packets are generally unable to improve the quality of the decoded picture. We will assume, in what follows, that the probability of not detecting an erroneous packet is zero (perfect detection). On the other hand, we note $P_e(c_l)$ the probability that a packet coded by the error correction code c_l and transmitted on the channel in question, is incorrect after decoding.

Given a global transmission rate R_T (source coding + channel coding), the optimization objective of the unequal protection consists in determining an optimal policy (or strategy) for allocating codes to the different data packets, according to a given performance measurement criterion. Note that a code allocation policy is defined as a sequence of codes

$$(9) \quad \Pi = \{c_{\pi}^1(N_{c_{\pi}^1}, K_{c_{\pi}^1}), c_{\pi}^2(N_{c_{\pi}^2}, K_{c_{\pi}^2}), \dots, c_{\pi}^{M_{\pi}}(N_{c_{\pi}^{M_{\pi}}}, K_{c_{\pi}^{M_{\pi}}})\}$$

Applying the error correction code to $c_i^{\pi} \in C$ the i th packet of data, taken of length equal to bits, $i = 1, 2, 3, \dots, M_{\pi}$; M_{π} being the number of packets to be transmitted using the π policy; it is also the index of the last transmitted packet. The overall transmission rate relating to the policy π is, then, given by:

$$(10) \quad R_{\pi} = \sum_{i=1}^{M_{\pi}} r_c(c_i^{\pi}) (bpp)$$

The constraint flow can therefore be expressed by inequality:

$$R_{\pi} \leq R_T$$

Table 1. PSNR Variation

image Rc	medical image	Boat image	Bird image
0.25	34.1187	26.8517	31.8187
0.5	35.6784	31.0784	37.3767
1	38.5614	34.9532	41.9540
1.5	40.6794	36.8675	44.5326
2	42.8871	39.2787	46.1684
2.5	45.0418	40.6976	48.1563
3	46.51385	43.9377	50.7068
	1.45675	0.85955	4.29677

Selection Algorithm for the Test Images

Selection algorithm for the test images is summarized in the flow chart of the Fig. 6. It goes, after choosing N images ($N=80$) and bit rates R_c for every image (in this paper, we took $R_c = 0,25,0,50, \dots, 300$, where $K=8$, through variances calculation [15] evaluation parameters by

$$(11) \quad \sigma_{PSNR_i}^2 = \frac{1}{K} \sum_{j=1}^K (PSNR_{i,j} - m_{PSNR_i})^2$$

With, $PSNR_i$ is value of evaluation images parameters $i=1, \dots, N$ and bit rates R_{c_j} , $j=1, \dots, K$, m_{PSNR_i} are evaluation parameters averages for N images, and every R_{c_j} , calculated as follows:

$$(12) \quad m_{PSNR_j} = \frac{1}{K} \sum_{j=1}^N PSNR_{i,j}$$

The last step of the algorithm consists of selecting M images among N previous choices, based on variances thresholds choices S_{PSNR} enabling to save only the images $i=1.....N$ according to the following rules:

$$\sigma_{PSNR_i}^2 \leq S_{PSNR}$$

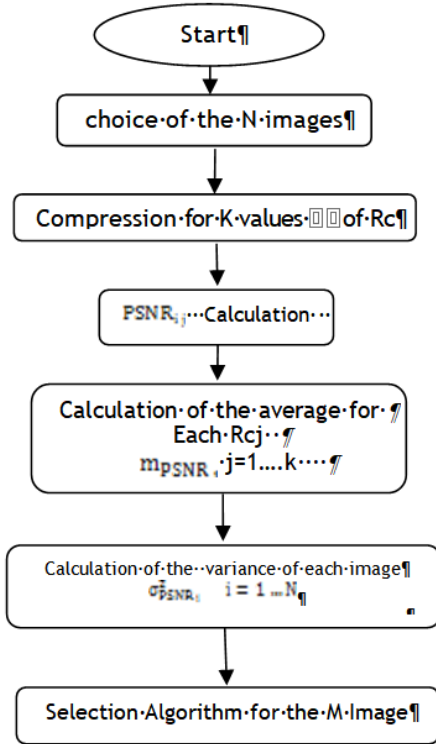

Fig.6. Chart of Selection Algorithm for Test Images

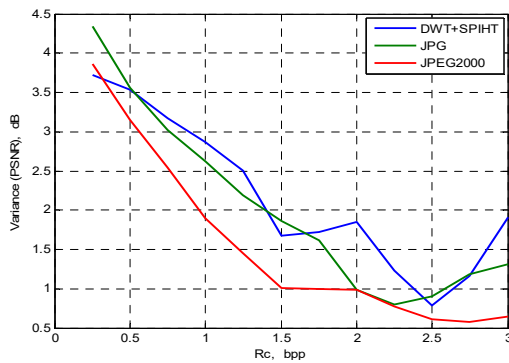

Fig.7. PSNR variation of the 15 selected natural test images

Optimization Criteria

Several performance measures can be adopted to characterize the performance of a given code allocation policy, and thus serve as criteria to be optimized.

Among these distortion measurements between the original image and the decoded image, there are:

- . Quadratic Mean Error (MSE).
- . The PSNR.

The bits number correctly decoded and used for the image reconstruction, or else the Useful Reconstruction Rate, which will be designated by DUR (criterion valid in the case of a nested source coding).

We give:

$$(13) \quad r_{\Pi,i} = \sum_{j=1}^i r_m(c_{\Pi}^j) \text{ (bpp)}$$

Describing the useful bit rate of image reconstruction when the $(i + 1)$ th packet is detected false.

We will, in what follows, give, for a policy:

$$\Pi = \{c_{\Pi}^1(N_{c_{\Pi}^1}, K_{c_{\Pi}^1}), c_{\Pi}^2(N_{c_{\Pi}^2}, K_{c_{\Pi}^2}), \dots, c_{\Pi}^{M_{\Pi}}(N_{c_{\Pi}^{M_{\Pi}}}, K_{c_{\Pi}^{M_{\Pi}}})\}$$

Given the respective means (mathematical expectations) of the MSE, noted $\overline{MQE_{\Pi}}$ of the PSNR, noted $\overline{PSNR_{\Pi}}$ and the Useful Rate of Reconstruction, noted $\overline{DUR_{\Pi}}$:

$$(14) \quad \overline{MSE_{\Pi}} = MSE(r_{\Pi,0})P_e(c_{\Pi}^1, p_b) + \sum_{i=2}^{M_{\Pi}} (r_{\Pi,i-1})P_e(c_{\Pi}^i, p_b) \prod_{j=1}^{i-1} [1 - P_e(c_{\Pi}^j, p_b)]$$

$$(15) \quad \overline{PSNR_{\Pi}} = PSNR(r_{\Pi,0})P_e(c_{\Pi}^1, p_b) + \sum_{i=2}^{M_{\Pi}+1} PSNR(r_{\Pi,i-1})P_e(c_{\Pi}^i, p_b) \prod_{j=1}^{i-1} [1 - P_e(c_{\Pi}^j, p_b)]$$

$$(16) \quad \overline{DUR_{\Pi}} = r_{\Pi,0}P_e(c_{\Pi}^1, p_b) + \sum_{i=2}^{M_{\Pi}+1} (r_{\Pi,i-1})P_e(c_{\Pi}^i, p_b) \prod_{j=1}^{i-1} [1 - P_e(c_{\Pi}^j, p_b)]$$

MSE (r) designates the function representing (in the absence of noise) the Mean Square Error (MSE) as a function of the rate r (in bpp) for the encoder of source used and in the case of the image to be transmitted.

$$(17) \quad PSNR(r) = 10 \log_{10} \left(\frac{255^2}{MSE(r)} \right) \text{ dB}$$

$P_e(c_{\Pi}^i, p_b)$ is the probability of an error at least at the i th packet (using the code) as a function of the probability P_b (probability of error per bit).

In the case of equal error protection EEP:

c_{Π}^i is constant. So it can be written:

$$(18) \quad \overline{MSE_{\Pi}} = P_e(c_{\Pi}, p_b) \sum_{i=1}^{M_{\Pi}+1} MSE(r_{\Pi,i-1}) [1 - P_e(c_{\Pi}, p_b)]^{i-1}$$

Therefore, it is necessary to determine the code (channel coding) which minimizes the distortion by

ensuring a maximum information transmission with the minimum of error.

$R_{c_{\Pi}} = \frac{K_{c_{\Pi}}}{N_{c_{\Pi}}}$ is characterized by the probabilities:

P_b : Probability of error per bit characterizing the channel.

And $P_e(c_{\Pi}, p_b)$: Probability of error per packet, for the code and for the probability P_b . One notes that a packet is considered erroneous if one detects at least one error in the packet.

These three performance measures lead to the following three optimization problems:

Problem I: minimization of the average MSE: $\min_{\Pi} \overline{MSE_{\Pi}}$ under the constraint $R_{\Pi} \leq R_T$

Problem II : maximization of average PSNR $\max_{\Pi} \overline{PSNR_{\Pi}}$ under the constraint $R_{\Pi} \leq R_T$

Problem III : maximizing the useful average of reconstruction: $\max_{\Pi} \overline{DUR_{\Pi}}$ under the constraint $R_{\Pi} \leq R_T$

It is noted that the performance measures used in Problems I and II (MSE and PSNR) are more representative of the quality of the reconstructed image than that used in Problem III.

Nevertheless, the advantage of the latter is that it does not use functions characterizing the performance of the source code in the case of the image in question (MSE (r) or PSNR

(r) functions). Therefore, it is not necessary to transmit to the receiver the code allocation policy that has been encoder level. We will, in the following, consider the problem 1.

Determination of optimal solutions

In our case it is assumed that the length of the packets at the output of the channel coder is fixed:

$N_{c_i} = N_{\Pi}$ Constant But the data packets to be coded are of variable length so the number of redundancy bits in each packet is variable. Therefore, to specify the number of source bits $K_{c_i}^1$ is equivalent to specifying the number of redundancy bits $N_{\Pi} - K_{c_i}^1$ in the i th packet.

In the case of the EEP protection, one must find the code

c_{Π} of yield $R_{c_{\Pi}} = \frac{K_{c_{\Pi}}^i}{N_{\Pi}}$ which minimizes the expression (13)

by ensuring a transmission of maximum information with the minimum of error.

But in the case of the UEP protection, it is necessary to determine for each packet the efficiency $R_{c_{\Pi}}^i = \frac{K_{c_{\Pi}}^i}{N_{\Pi}}$ of the

encoder correctors $c_{\Pi}^i(N_{\Pi}, K_{c_{\Pi}}^i)$ which minimizes the expression (9) by ensuring a maximum information transmission with the minimum of error.

The code $c_{\Pi}^i(N_{\Pi}, K_{c_{\Pi}}^i)$ is chosen from L error correcting codes:

$$C = \{c_1(N_{\Pi}, K_{c_1}), c_2(N_{\Pi}, K_{c_2}), \dots, c_L(N_{\Pi}, K_{c_L})\}$$

So we have ML possible combination of Code Rates, with P is the number of turbochargers different yield and M is the number of packets to transmit.

In our simulation, we adopted a simple optimization method, consists in finding in the EEP protection for the set of packets With $\mathcal{E} = 10^{-2}$.

Optimization (RS) Code Steps by the Whale Algorithm (WA) of EEP Protection

Step 1: Select Performance R.

Step 2: Extract the RS (M, t) code input parameters according to the R output.

Step 3: Apply the RS code (M, t) parameters on the set of packets.

Step 4: Inject the Channel noise on the set of packets.

Step 5: Correct the erroneous bits.

Step 6: If (MSE of the reconstructed image - MSE of the received image) $\leq \mathcal{E}$. with min redundancy bits

End

Step 7: If not go to step 1.

For UEP protection by protecting more important packets for image reconstruction . With $\mathcal{E} = 10^{-2}$

This algorithm is more efficient than those used in the literature. And its main advantage is its speed and rapid convergence.

Optimization (RS) Code Steps by the UEP Protection Whale Algorithm (WA)

Application to solomon reed

The flow allocation optimization

Step 1: Select the R_i Code Rates.

Step 2: Extract the encoder input parameters RS (M_i, t_i) for each output R_i .

Step 3: Apply RS encoder parameters (M_i, t_i) on each packet.

Step 4: Inject the Channel noise on each packet to transmit.

Step 5: Correct the erroneous bits.

Step 6: Group the packages

Step 7: rebuild the received image.

Step 8: If (MSE of the reconstructed image - MSE of the received image) $\leq \mathcal{E}$.

with min redundancy bits

End

Step 9: If not go to step 1.

method presented above is applied to the image transmission system of Fig. 8. The medical image is taken as a test image. The transmission is done on a symmetrical binary bit error rate channel varying from 10-3, 10-2 and 10-1. For each BER of the channel, optimization is performed for a rate value: CR = 0.25 bpp.

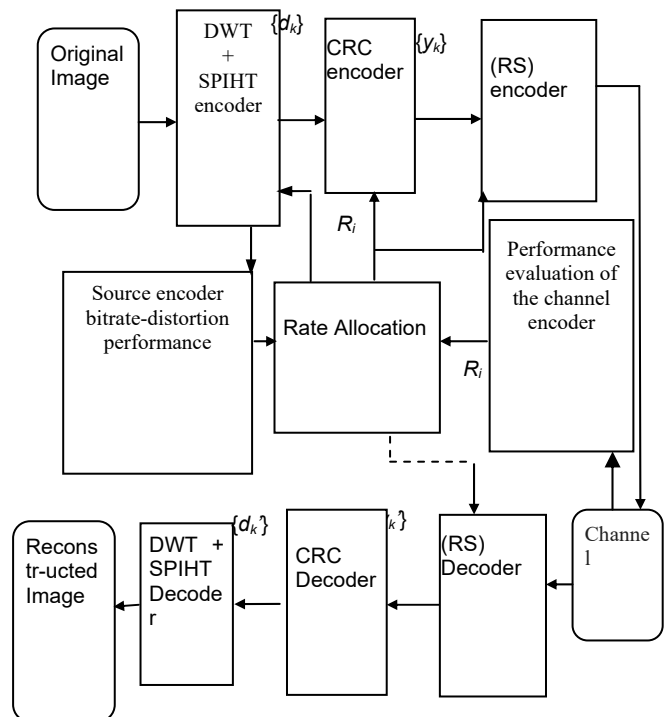

Fig.8. Applied to the image transmission system

The data delivered by the DWT+SPIHT encoder is partitioned into consecutive blocks of size (R_i-16) bits each. It is assumed that the channel coding strategy is done in two steps: an error-detector coding (CRC) followed by an error-correcting coding (reed solomon code: (RS)). The role of error detection is to interrupt the decoding of the first detected error and therefore to reject the bits that can contribute to the propagation of errors. At the receiver, the decoding is stopped at the first detected erroneous packet, since the following packets are generally unable to improve the quality of the decoded picture. The CRC encoder adds 16 redundancy bits to each block.

The resulting data is transmitted on a channel without memory. At the receiver, the RS is decoded. The use of these codes makes it possible to have very high coding efficiencies giving rise to a better spectral efficiency of the system. However, for the choice of coding efficiencies, it is often necessary to use genetics for the automatic selection. For this, we consider a set of 08 different yield codes: {0.2, 0.3, 0.4, 0.5, 0.6, 0.7, 0.8, 0.9}. These codes are derived from an RS. All results are based on a packet length of 16386 bits at the output of the channel encoder.

For each BER of the channel, the optimal code allocation policies according to the minimization criteria of the average MSE (Problem I), are determined by the source coder

considered: DWT+SPIHT. This problem has been chosen for its effectiveness in optimizing the proposed system.

For BER = 0.001
 PSNR_{rec}: reconstructed PSNR
 PSNR_{req}: PSNR received

Table 2. versus BER of a BSC channel for both medical image , Boat and Bird images (512 × 512) For BER = 0.001.

CR (0.25 bpp)	BER of channel 0.001			Redundancy bits
	04 packets			
	PSNR _{rec}	Code Rates	PSNR _{req}	
medical image	34.1187	0.8 0.9 0.9 0.9	34.1038	5353
Boat image	26.8517	0.7 0.7 0.8 0.8	26.8404	12514
Bird image	31.8187	0.7 0.7 0.8 0.9	31.7843	10301

Table 3. Versus BER of a BSC channel for both medical image, Boat and Bird images (512 × 512) For BER = 0.01.

CR (0.25 bpp)	BER of channel 0.01			Redundancy Bits
	04 packets			
	PSNR _{rec}	Code Rates	PSNR _{req}	
medical image	34.1187	0.3 0.5 0.5 0.6	31.6553	27557
Boat image	26.8507	0.3 0.6 0.6 0.7	25.7183	24303
Bird image	31.8076	0.3 0.5 0.6 0.8	29.9734	21.652

Table 4. Versus BER of a BSC channel for both medical image, Boat and Bird images (512 × 512) For BER = 0.1.

CR (0.25 bpp)	BER of channel 0.1			Redundancy Bits
	04 packets			
	PSNR _{rec}	Code Rates	PSNR _{req}	
medical image	34.1187	0.2 0.2 0.2 0.3	27.8189	50355
Boat image	26.8507	0.2 0.2 0.2 0.2	20.9071	47114
Bird image	31.8076	0.2 0.2 0.3 0.3	23.7152	43562

We have shown in Table 5 the respective variations of the optimal PSNR. The coding system performance introduced by [16], [17] and [18] is presented.

Table 5. PSNR versus BER of a BSC channel for the medical image 512 × 512.

Total CR (0.25 bpp)	BER of channel 0.01	
	Code Rate	PSNR
Sachs et al. (mother rate 1/2) [16]	0.30	27.90
Thomos et al. "TCS-UEP" [12]	0.33	28.64
Thomos et al. "TCSD-UEP" [17]	0.33	28.73
UsamaSayed et Safwat M "UEP" [18]	0.29	30.32
Proposed system	0.47	31.65

Tables 2, 3, 4 and 5 show, in fact, that the proposed algorithm often allows to find an optimal solution of the problem I.

It is obvious that the performances obtained by applying the UEP protection are better than those obtained by applying the EEP protection.

Conclusion

In this paper, we considered the rate allocation optimization between a nested source encoder and a channel encoder, for a transmission of still images through a BSC channel. We retained the reed solomon (RS) code for data protection because they offer the best performance, in error correction terms, on a binary output channel. We have proposed the unequal protection optimization by different RSs, of the progressive bit stream delivered by the source code. An error detection provided by the CRC codec makes it possible to stop the decoding at the first detected erroneous block and to reconstruct the image from the blocks that are supposed to be correct.

We considered a transmission on a BSC channel two optimization criteria were presented: Quadratic Mean Error (MSE), peak signal-to-noise ratio (PSNR). The optimization method developed will be applied to the DWT+SPIHT encoder for compression of the source image. Our simulations have shown that, in the context of coding and transmission considered, the optimal performances obtained with the DWT+SPIHT coder are very close. We also noted that the criterion of MSE optimization is the most relevant criterion, as it ensures a better minimum quality of the decoded image at the expense of a slight degradation of the decoded PSNR in the first time with errors absence. Finally, the gain provided by the application of unequal protection (compared to uniform protection) depends both on the source encoder used and the error correction codes considered.

Acknowledgements

We gratefully thank the Directorate General for Scientific Research and Technological Development (DGSRTD) affiliated with the Ministry of Higher Education and Scientific Research in Algeria, for his support of our laboratory.

Authors: Dr. Larbi MOURAD, Laboratory: INFORMATION PROCESSING AND TELECOMMUNICATION LABORATORY Faculty of Technology Bechar University Independence Street Béchar Algeria, email : mourad.larbi@univ-bechar.dz
 Ph.D. Khelifi MUSTAPHA, Laboratory: INFORMATION PROCESSING AND TELECOMMUNICATION LABORATORY Faculty of Technology Bechar University Independence Street Béchar Algeria, email : khelifi_m@yahoo.fr
 Ph.D. Lahcene MOHAMED RIDA, Laboratory: INFORMATION PROCESSING AND TELECOMMUNICATION LABORATORY institute of Technology Naama center University Independence Street Naama Algeria, email : lahcenereda1@gmail.com

REFERENCES

- [1] Amir Said and William A. Pearlman. "A new fast and efficient image codec based on set partitioning in hierarchical trees " IEEE Transactions on Circuits and Systems for Video Technology, 6(3):243.250, June 1996.
- [2] Lewis,A.S.; Knowles,G. " Image Compression Using the 2-D Wavelet Transform, " IEEE Trans. on Image Processing, Vol. 1 . NO. 2, PP. 244 - 250, APRIL 1992.
- [3] S.Zaibi "Optimisation conjointe du codage (décodage). source canal pour la transmission d'images". Thèse de doctorat à l'ENST Bretagne, Février 2004.
- [4] J. M. Shapiro. "Embedded image coding using zerotrees of wavelet coefficients" IEEE Transactions on Signal Processing, 41(12):3445.3462, December 1993.
- [5] D. Taubman. "High performance scalable image compression with EBCOT " IEEE Transactions on Image Processing, 2000.
- [6] Jianxiong corvisier.Ph. "La Norme Jpeg Adopte Les Ondelettes " revue Electronique n°95 (septembre 1999),page 15-16
- [7] Serap Çekli ; Ali Akman,'An efficient SPIHT algorithm and system architecture for image compression',Signal Processing and Communications Applications Conference (SIU), 2017 25th
- [8] S. NirmalRaj,'SPIHT: A Set Partitioning in Hierarchical Trees Algorithm for Image Compression',Contemporary Engineering Sciences, Vol. 8, 2015, no. 6, 263 – 270
- [9] D. G. Sachs, A. Raghavan, and K. Ramchanran, "Wireless Image Transmission using Multiple-Description based Concatenated Codes," the Data Compression Conf., 2000.
- [10] A. Kaveh , M. Ilchi Ghazaan, Enhanced whale optimization algorithm for sizing optimization of skeletal structures, Mechanics Based Design of Structures and Machines An International Journal,21 Jul 2016,Pages 345-362
- [11] Hongping Hu, Yanping Bai, and Ting Xu,Improved whale optimization algorithms based on inertia weights and their applications,International Journal Of Circuits, Systems And Signal Processing,Volume 11, 2017
- [12] Ying Ling , Yongquan Zhou , Qifang Luo, Lévy Flight Trajectory-Based Whale Optimization Algorithm for Global Optimization, IEEE Access (Volume: 5), 19 April 2017,Pages 6168 - 6186
- [13] Marwa Sharawi , Hossam M. Zawbaa , E. Emary , Hossam M. Zawbaa , E. Emary, Feature selection approach based on whale optimization algorithm,Ninth International Conference on Advanced Computational Intelligence (ICACI), 2017
- [14] Vimal Kumar Pathak , Amit Kumar Singh, Accuracy control of contactless laser sensor system using whale optimization algorithm and moth-flame optimization, Plattform für Methoden, Systeme und Anwendungen der Messtechnik, Volume 84, Issue 11 (Nov 2017)
- [15] Bases du traitement des images " Opérations De Base Et Améliorations " Matthieu Cord Transparents de cours préparés par S. Dubuisson, D. Béréziat, N. Thome 2016.
- [16] Ping Liu, Guanfeng Li,'An Improved SPIHT Algorithm for Image Compression in Low Bit Rate',Communications and Network, 2013, 5, 245-248
- [17] N. Thomos, N.V. Boulgouris, and M.G. Strintzis, "Wireless Image Transmission Using Turbo Codes and Optimal Unequal Error Protection," IEEE Trans. Image Proc., vol.14, no. 11, pp. 1890-1901, Nov. 2005.
- [18] S.M Usama and M. R. Safwat "An efficient rate allocation scheme for transmission of image streams over binary symmetric channels"Journal of Engineering Sciences, Assiut University, Vol. 35, No.1, pp.177-188, January 2007