

doi:10.15199/48.2022.04.23

Adaptive Neuro-Fuzzy Controller Based STATCOM for Reactive Power Compensator in Distribution Grid

Abstract. Compensation of reactive power is necessary for reduction the effects caused by the inductive load. To achieve these issues, the utilize power electronics devices are used to control the reactive power flow using static synchronous compensator STATCOM. It is a shunt connected FACTS compensator that provide/withdraw reactive power. This approach is implemented to enhance voltage drop in distribution grid. In this paper, an adaptive neuro-fuzzy logic controller based STATCOM is proposed to regulate the bus voltages of IEEE 9 bus 33kV distribution grid. Method of dq transformation is used for reactive power calculation due to its high accuracy and simple application. Adaptive controller designed based on Sugeno type fuzzy logic rules show that the compensator increases bus voltage about 19%, with damping oscillation during step change compared with the conventional PI controllers.

Streszczenie. Kompensacja mocy biernej jest konieczna do zmniejszenia skutków wywołanych obciążeniem indukcyjnym. Aby osiągnąć te problemy, wykorzystuje się urządzenia energoelektroniczne do sterowania przepływem mocy biernej za pomocą statycznego kompensatora synchronicznego STATCOM. Jest to kompensator FACTS połączony z bocznikiem, który dostarcza/odbiera moc bierną. Takie podejście jest wdrażane w celu zwiększenia spadku napięcia w sieci dystrybucyjnej. W niniejszym artykule zaproponowano adaptacyjny sterownik logiki neuro-rozmytej oparty na STATCOM do regulacji napięć magistrali sieci dystrybucyjnej IEEE 9 33 kV. Metoda transformacji dq jest wykorzystywana do obliczania mocy biernej ze względu na jej dużą dokładność i prostą aplikację. Sterownik adaptacyjny zaprojektowany w oparciu o zasady logiki rozmytej typu Sugeno pokazuje, że kompensator zwiększa napięcie szyny o około 19%, z tłumieniem drgań podczas zmiany skoku w porównaniu z konwencjonalnymi sterownikami PI. (Adaptacyjny sterownik STATCOM oparty na neuro-rozmytym kontrolerze dla kompensatora mocy biernej w sieci dystrybucyjnej)

Keywords: STATCOM, adaptive neuro fuzzy controller, voltage enhancement, reactive power controller.

Słowa kluczowe: STATCOM, sterownik, sieci neuronowe, logika rozmyta.

Introduction

Reactive power compensation is a critical issue in power system control. This type of power increases line losses and reduces the capability lines power transfer capability. Furthermore, reactive power should not be transmitted over a longer distance via the power line. Hence to address these issues, AC flexible systems that are adaptable static compensators STATCOM, unified power flow controllers UPFC, and static volt-ampere compensators SVC are used [1]. Shunt capacitive has long been used for reactive power compensation. This type of compensation increases power transfer capacity while also improving "transient stability." The tool's significant drawbacks are its limited range compensation capability and relaxed response. AC flexible system that is adaptable FACTS are new technology controllers developed by electric utilities to address the issues mentioned [2]. FACTS controllers can improve power system dynamic and steady-state performance by controlling network parameters like line impedance, terminal voltage, and burden angle [3]. FACTS gadgets offer variable equal remuneration, which is exceptionally compelling at controlling and further developing line security and power stream. By infusing controllable voltage (magnitude and angle) in corresponding with the distribution framework, the equal compensator in light of the static coordinated compensator STATCOM can give virtual compensation to the power line impedance [4]. Lately, new ways to deal with computerized mentality have been proposed to plan a STATCOM-based regulator. Particle swarm optimization PSO [5, 6], the genetic algorithm [7, 8], and the multiobjective evolutionary algorithm [9] are among the new approaches. Since 1988, the artificial neural network ANN methodology has piqued the interest of many power engineering utilizations. Power system stabilizers, cost-effective load dispatching, and other applications fall into this category. These applications' results demonstrated that ANN regulators have a high potential for further developing power framework disconnected and online applications [9]. For parallel FACTS device, STATCOM, the

neuro-fuzzy controller (an ANN controller based on fuzzy control) is used. In this paper, the authors will create a neuro-fuzzy controller-based STATCOM for power flow control and voltage dip enhancement in an IEEE 33kV nine-bus distribution grid.

Reactive power compensation

Figure 1 depicts a AC line circuit diagram and its boundaries, as well as its phasor graph, which portrays the connection among currents and voltages [10]. It is obvious that a relationship exists between the voltages at the sending and receiving ends, as well as the magnitude and phase difference variations. The load reactive component current, I_x , is responsible for the majority of the drop voltage in ($V_1 = jI_x X_L$). There are two types of control actions that can be used to keep the voltages close to the rated value:

1. load type compensation.
2. system type compensation.

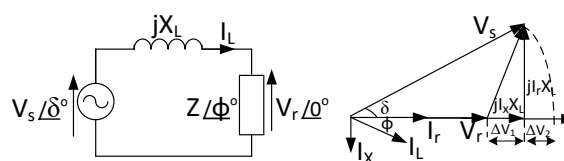

Fig.1. A short, lossless AC line feeding a load

In load type compensation this compensation is possible by adding a parallel capacitive load that compensate the reactive load current I_x where $I_c = -I_x$. Doing so give the effective by increasing the combination power factor to become unity [11]. The absence of reactive load current mitigates or eliminates the drop voltage ΔV_1 , and this will be bringing receiving voltage V_r closer in its magnitude to sending voltage V_s , this condition is called load type compensation. As shown in Figure 2, the reactive power compensation regulates the desirable end voltage at the evaluated esteem, a power utility might introduce a responsive power compensator.

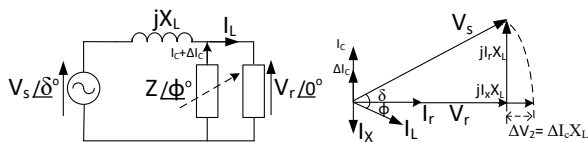

Fig. 2. Reactive power control for voltage regulations

To repay the voltage distinction ΔV_2 , an extra of capacitive current, ΔI_c , over I_c that compensates for I_x , is drawn by the compensator. Whenever $\Delta I_c X_L = \Delta V_2$, the not exactly helpful end voltage V_r , approaches the sending-end voltage V_s . Such compensators are used by power utilities to ensure the idea of supply to their clients [12]. This is the basic idea of the reactive compensation. In this paper, we use STATCOM, a high speed response power electronics switches based shunt reactive compensator.

Voltage versus reactive power flow in the grid

The voltage fluctuation in the grid mainly has two factors. First is the reactive power stream change in the framework. The second is the load change associated with the grid. Along these lines, the voltage framework is firmly connected with the reactive power stream [13]. Under any working load condition, the receptive force of the generation terminal must be in balance with the responsive power expected by the heap terminal. In terms of the supply system, which is a three-stage inverter, and the distribution network, which is an ideal source, the power conveyed by the line system is obtained:

$$(1) \quad P = VI \cos \phi = \frac{V_s V_r}{X} \sin \delta$$

$$(2) \quad Q = VI \sin \phi = \frac{V_s V_r}{X} \cos \delta - \frac{V^2}{X}$$

where: V_s , V_r are the source and load voltages respectively, I_L refers to the load current and the angles δ and ϕ are clarified in Figure 2.

When the grid system's load is fixed, the active power is predictable. At this operating point in simultaneous (1) and (2) where:

$$(3) \quad Q = \sqrt{\left(\frac{V_s V_r}{X}\right)^2 - P^2} - \frac{V^2}{X}$$

Voltage versus reactive power relation that required by the operating load is:

$$(4) \quad Q = \frac{V^2}{X}$$

If the power source reactive power output remains constant as the reactive load increases, this causes an unbalance between the power supply reactive power and the load terminal at the rated voltage, causing the system voltage to fall [14]. Otherwise, if the reactive power of the power supply exceeds the reactive load demand, the system will operate at a voltage higher than the rated voltage level.

Reactive power flow controlled based on STATCOM

STATCOM is one of the custom FACTS devices. Static VAR Compensator used at the Distribution grid. The VSC is the main component of the STATCOM as shown in Figure 1, that is based on high rating of power electronics devices technologies, that is a versatile device for injection or absorb reactive power from and to ac grid [15]. STATCOM is comparable to the customizable voltage source or current the source that can be obliged by its abundance and angle to change the responsive power passed on to the network.

The control of receptive power is accomplished through the guideline of a controlled voltage source behind the spillage impedance of a transformer, similarly to an ordinary coordinated compensator as displayed in Figure 3.

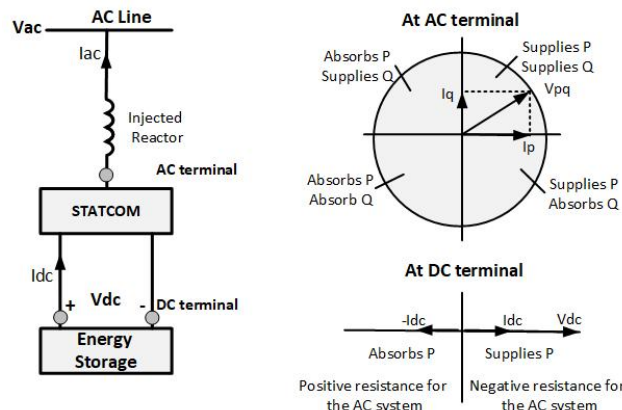

Fig. 3. STATCOM characteristics

Nevertheless, not in any way like the other coordinated compensator, which is basically a simultaneous generator where change the oversaw voltage done on account of progress in the field current, the STATCOM utilizes voltage source converter VSC, to accomplish a similar guideline task. Quick control of VSC grants STATCOM to have a reaction rate quickly [16]. The SVC static VAR compensator is also solid-state type. The operating of SVC as a shunt connected, SVC have passive elements like capacitor and inductor, where inductive or output currents of the capacitor can be controlled autonomously from its association with the AC transport voltage. The benefit of the quick exchanging reaction normal for converters, the STATCOM furnishes a quicker reaction as contrasted and SVC. It is shunt-associated, responsive remuneration hardware, which is able to do "creating and additionally retaining reactive power" whose result can be acclimated to keep up with control of explicit boundaries of the electric power framework. The STATCOM current conveyed displayed in Figure 4 is communicated as [17]:

$$(5) \quad I = \frac{V_{STATCOM} - V_s}{X}$$

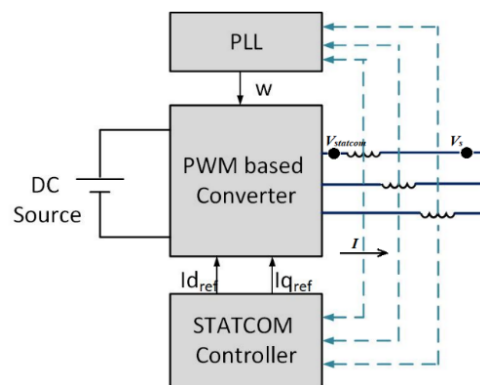

Fig. 4. STATCOM basic configuration

Regardless of the STATCOM switching losses and its impact on the entire real power, the voltages $V_{STATCOM}$ and V_s are almost in phase. Reactive power Q that consumed by the STATCOM gadget can be communicated as:

$$(6) \quad Q = \frac{V_{STATCOM} - V_S}{X} V_{STATCOM}$$

The two voltage phases should be congruent in the ideal case, according to Equation (6). The magnitude of $V_{STATCOM}$ can be used to control the angle and amplitude of STATCOM current consumed or conveyed from/to the AC line [18]. When $V_{STATCOM}$ is less than V the grid voltage, the current flow from the grid to the STATCOM device lags the grid voltage by 90° , which is emulated as inductance, and vice versa, which is emulated as capacitance and provides reactive power to the grid, where STATCOM in this case leads the grid voltage V by 90° [19]. The operation of STATCOM for provides inductive or capacitive reactive power support to the power grid shown in Figure 5.

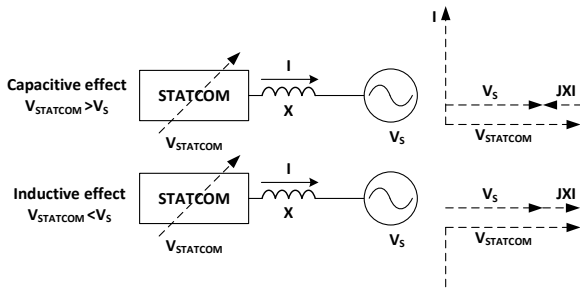

Fig.5. Concept of reactive compensation

Whenever the voltage network is decreased or raised to an ostensible worth, the STATCOM is restricted by the rating limit of the accessible its switching gadgets. Hence, the STATCOM current will stay unaltered. Because of the consistent case, the amplitude and angle change of $V_{STATCOM}$ for reactive power compensation. For estimating reactive power, the dq hypothesis was utilized [20]. This hypothesis depends on time space, and it is valid for activity in consistent state or transient state, as well concerning conventional voltage and current power framework waveforms. The effortlessness of computations gives one more benefit normal for this hypothesis, which incorporates arithmetical estimation special case for the need of isolating the mean and rotated qualities for the determined power components. The d-q hypothesis plays out a change known as "park transformation" of a fixed directions reference framework abc to dq pivoting facilitates reference [22]. The transformation applied to time-domain for voltages and currents in the natural frames are as follows:

$$(7) \quad \begin{bmatrix} v_d \\ v_q \\ v_0 \end{bmatrix} = \frac{2}{3} \begin{bmatrix} \cos(\phi) & \cos(\phi - \frac{2\pi}{3}) & \cos(\phi + \frac{2\pi}{3}) \\ -\sin(\phi) & -\sin(\phi - \frac{2\pi}{3}) & -\sin(\phi + \frac{2\pi}{3}) \\ \frac{1}{2} & \frac{1}{2} & \frac{1}{2} \end{bmatrix} \begin{bmatrix} v_a \\ v_b \\ v_c \end{bmatrix}$$

$$(8) \quad \begin{bmatrix} i_d \\ i_q \\ i_0 \end{bmatrix} = \frac{2}{3} \begin{bmatrix} \cos(\phi) & \cos(\phi - \frac{2\pi}{3}) & \cos(\phi + \frac{2\pi}{3}) \\ -\sin(\phi) & -\sin(\phi - \frac{2\pi}{3}) & -\sin(\phi + \frac{2\pi}{3}) \\ \frac{1}{2} & \frac{1}{2} & \frac{1}{2} \end{bmatrix} \begin{bmatrix} i_a \\ i_b \\ i_c \end{bmatrix}$$

$$(9) \quad \phi = (\omega t + \theta)$$

Where ϕ is the phase angle between the rotating and fixed coordinate system at each time and θ the voltage phase shift. The reactive power compensated calculated from (7) and (8) is:

$$(10) \quad q = V_d I_q - V_q I_d$$

STATCOM control scheme

The block chart of control system of STATCOM is shown in Figure 6. The line voltage and current are sensed and from that measurement the reactive power Q is calculated by park transformations. The measured reactive power fills in as input for shut circle control. For generating error-signal Err_{rq} , the ideal worth q_{ref} is compared to the measured q . This error signal is processed in the controller, which does the following:

$$(10) \quad Error_q = q_{ref} - q$$

The angle of the embedded voltage can be changed by changing the indication of the sign to make the compensation in capacitive or inductive mode. Figure 6 shows the detailed neuro fuzzy logic controller based STATCOM for reactive power flow. The modulation index is controlled based on the error in reading of reactive power using ANFIS control system.

$$(11) \quad \psi = \phi \pm \gamma$$

In capacitive/inductive mode operations, the sign of the Err_{rq} in (10) γ can be adjusted.

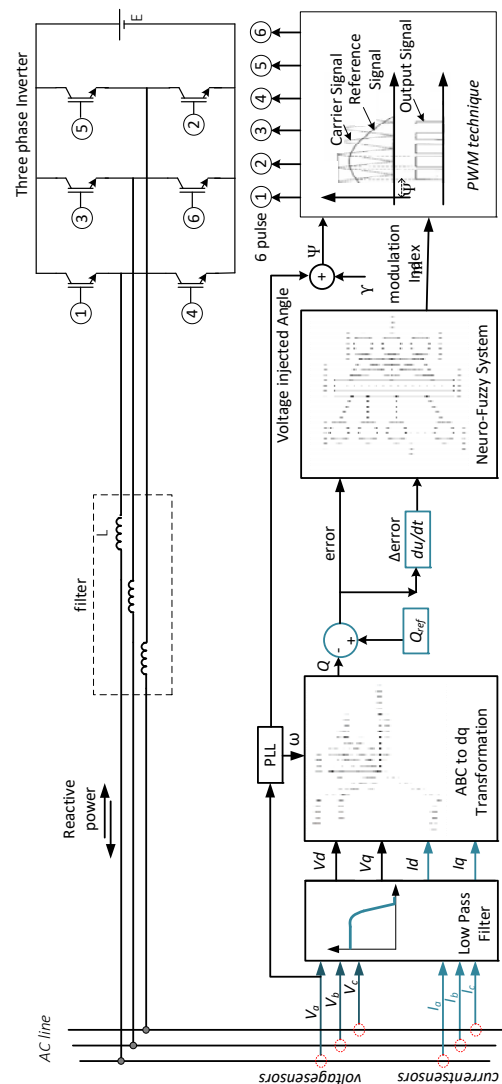

Fig.6. ANFIS based STATCOM control system

Neuro-fuzzy control system

Modern control using fuzzy logic is suitable for uncertain system, especially for the system with difficult to derive its mathematical model. Fuzzy logic control FLC plays an crucial role in many of factual applications [23]. There are many kinds of fuzzy surmising components, the Takagi-Sugeno TS-fuzzy is picked in this work. To tune the participation the artificial neural organization will be utilized with a TS-fuzzy like-PI regulator. TS-fuzzy regulator has an exceptionally non-straight with variable addition regulator. It creates wide varieties range gain of the regulator. Subjective choice regulator boundaries might prompt a satisfactory reaction or flimsiness framework. Better response may be achieved by using combined of ANN and fuzzy logic in neuro-fuzzy system for adapting the boundaries and rules of fluffy by utilizing ANN learning calculation. Such system can be trained without need to expert knowledge commonly required for the standard type of FCL, also the rules base can be reduced. Input boundaries and result participation MF's are determined during the preparation stage [24]. The learning calculation objective is changing the information boundaries and result in MFs so the best result matching is accomplished for the planned controller. A cross breed learning system "slope plunge GD and least-squares gauge LSE" is typically applied to for distinguishing the boundaries of the network [25]. In this study the input universe of discourse is split into 7-triangle MFs with overlapping of 50%, then for inputs Q_{error} and ΔQ_{error} "two inputs", with control rule of 49 consequents the linear functions need to be determined. To tune the rules of TS by using neuro-fuzzy, one set of data is need to be generated. Input data to the controller is a data vector of Errorq results as in equation 11, controller output are "modulation index" m and phase angle ψ respectively. To initialise the coefficients of the consequents, Mamdani fuzzy like PI controller described in Table 1 is used to start the training procedure, error and change of error relation. STATCOM control system block diagram is shown in Figure 6. Yield surface of STATCOM-control planned is displayed in Figure 7. This method is performed utilizing the GUI of the neuro-fuzzy document remembered for the MATLAB/fuzzy rationale tool stash. this preparing technique is applied for three phase system.

Table 1. The parameters of the sensor

Error/ Δ Error	HB	HM	HS	ZO	LS	LM	LB
HB	HB	HB	HM	HS	ZO	ZO	ZO
HM	HB	HB	HM	HS	HS	ZO	ZO
HS	HB	HM	HS	HS	ZO	PS	PS
ZO	HM	HM	HS	ZO	LS	LM	LM
LS	HM	HS	ZO	LS	LS	LM	LB
LM	ZO	ZO	LS	LS	LM	LB	LB
LB	ZO	ZO	LS	LM	LM	LB	LB

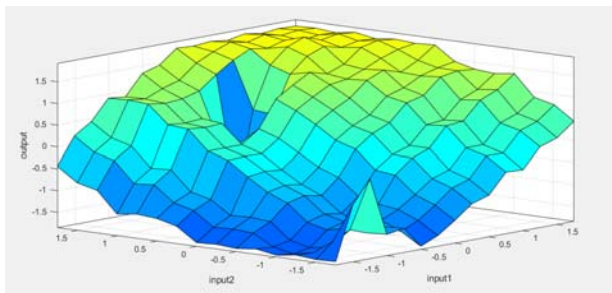

Fig.7. ANFIS validation surface

Simulation and results

A power framework comprising of nine buses, three generators is displayed in Figure 8. STATCOM installed at

weak bus (Bus-6) for controlling the flow of reactive power and enhancing its associated voltage.

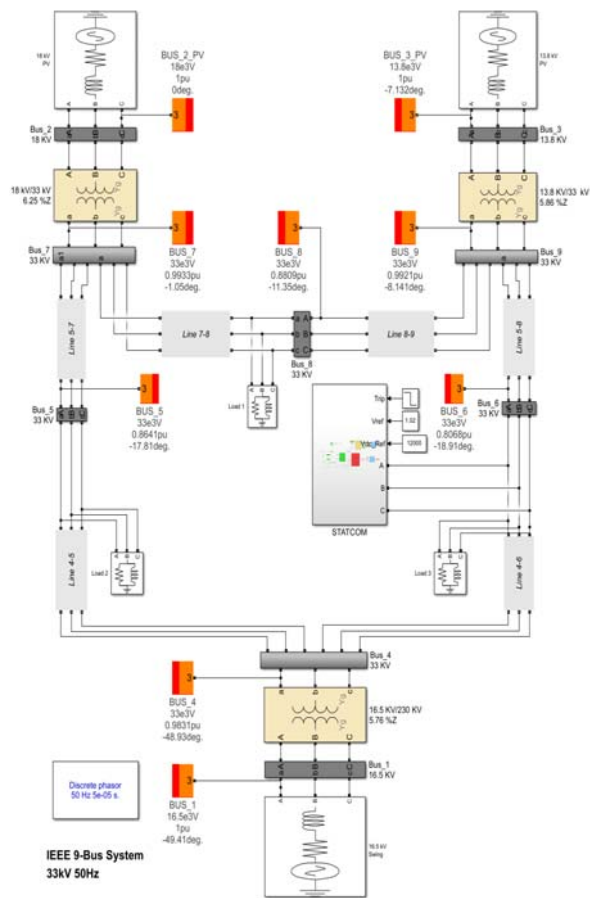

Fig.8. IEEE 33 kV 9-bus system with MATLAB/Simulink

As shown in Figure 8, simulation based on discrete phasor mode 50Hz takes a sample time of 50 microseconds. A DC voltage source is provided to a compensator which helps in absorbing or feeding the reactive power. At steady state condition, bus voltages are shown in Figure 9. It's clear that bus-6 is the weakest bus with voltage of 0.8 pu. Test starts by step changing the injected voltage of STATCOM. compensation process by injected the controllable voltage $V_{STATCOM}$ that feeding the reactive power to compensate the voltage at bus-6. Figure 10 shows the action of STATCOM at $t=0.5$ sec.

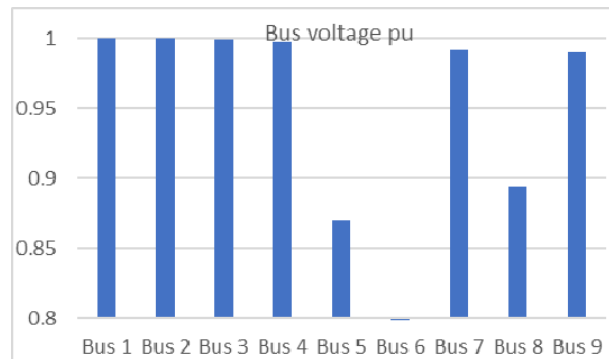

Fig.9. Bus voltages before compensation in pu

In this case, $V_{STATCOM}$ greater than the line voltage, and the compensator acts as a capacitive, the voltage increased to about 0.99 pu with an increase ratio of about 19%. Figure

11 shows the STATCOM current in pu during compensation. A steady state current is about 0.43 pu, for 100 MVA base power, is required to compensate a large voltage dip (about 20%). Figures 12 and 13 show the active and reactive power injected to the grid. The injected reactive power is about 0.7 pu while no change in active power at steady state.

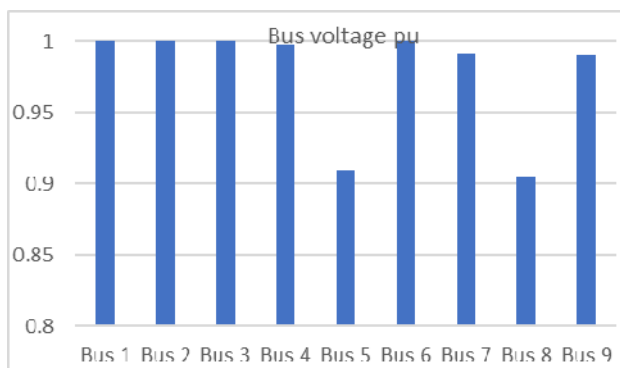

Fig.10. Bus voltages after compensation in pu

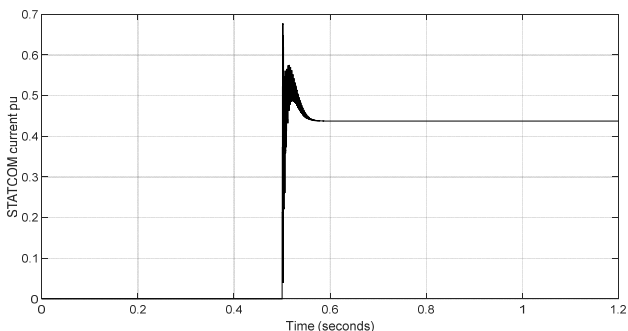

Fig.11. STATCOM current during compensation

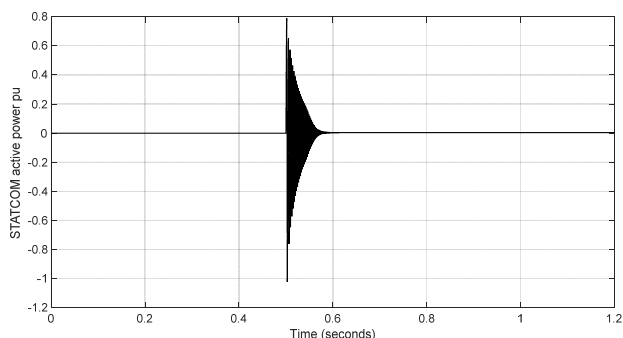

Fig.12. STATCOM active power during compensation

Figure 14 shows the Power-Voltage curve with and without STATCOM it's shown that a knee point increased by using STATCOM.

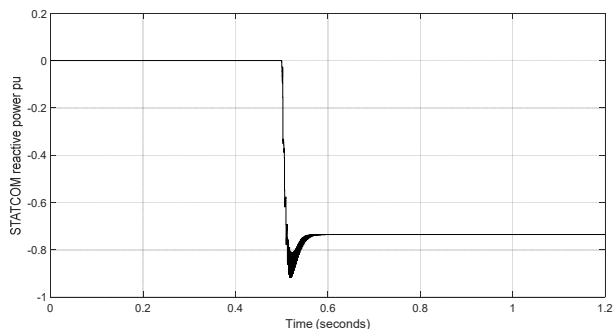

Fig.13. STATCOM reactive power during compensation

To validate the designed controller, a conventional PI was used to compare the response against step change in the load. Figure 15 shows the comparison between two types of controllers, it's clear that ANFIS (neuro fuzzy controller) has less overshoot and faster in reach the steady state condition.

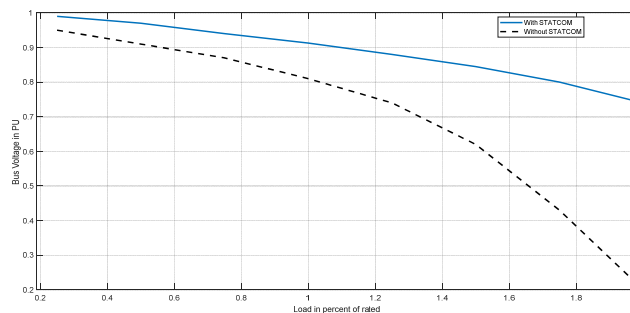

Fig.14. Voltage vs. power characteristic

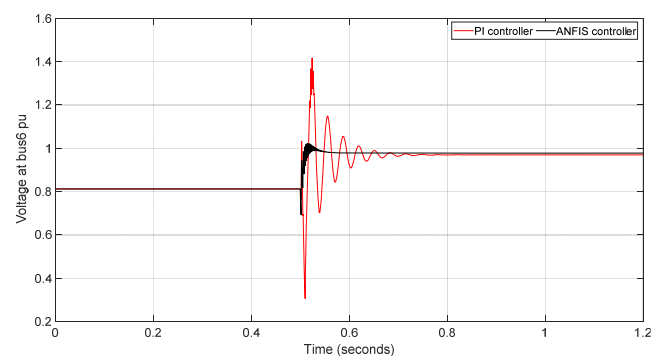

Fig.15. Voltage response with PI and ANFIS controller

Conclusion

A reactive power flow control and voltage are adjacent for IEEE 9-bus 33 kV distribution network using neuro fuzzy logic controller based STATCOM. A circuit has been modelled and simulated using MATLAB/Simulink 50Hz discrete phasor mode. STATCOM modifies the controllable voltage's amplitude and phase angle. It injects a controllable voltage to dominate the power in the alternating current line and boost the bus voltage. A neuro fuzzy logic controller was intended for the STATCOM control circuit. Simulation results show that the significant management of reactive power in bus-6 which increased the voltage about 19% also the STATCOM increase the knee point in power-voltage characteristic this will delay the voltage collapse. In other hand, neuro fuzzy controller enhances the response of STATCOM during compensation instant and modify the stability of the system.

Authors: dr Mahmood T. Alkhayat. Mosul, Iraq, Northern Technical University, E-mail: m.t.alkhayyat@ntu.edu.iq, dr Mohammed Y. Suliman. Mosul, Iraq, Northern Technical University, E-mail: mohammed.yahya@ntu.edu.iq

REFERENCES

- [1] R. M. Monteiro Pereira and et al, Comparative study of STATCOM and SVC performance on Dynamic Voltage Collapse of an Electric Power System with Wind Generation, IEEE Latin America Transactions, vol. 12, no. 2, pp. 138-145, 2014, doi: 10.1109/TLA.2014.6749530
- [2] Johnson R. K. Varma and E. M. Siavashi, PV-STATCOM: A New Smart Inverter for Voltage Control in Distribution Systems, IEEE Transactions on Sustainable Energy, vol. 9, no. 4, pp. 1681-1691, 2018, doi: 10.1109/TSTE.2018.2808601

- [3] M. T. Alkhayyat¹ and S. M. Bashi, A New Survey for Optimum Power Flow with Facts Devices, *International Journal of Electrical & Electronic Systems, OMICS*, Vol 5, Issue 4, 2016
- [4] M. Y. Suliman and R. K. Antar, Power flow controller based on a new proposed statcom controller, *International Journal of Engineering & Technology*, vol 7, no 4, pp. 3826-3829, 2018
- [5] O. M. Kamel and et al, A Novel Hybrid Ant Colony-Particle Swarm Optimization Techniques Based Tuning STATCOM for Grid Code Compliance, in *IEEE Access*, vol. 8, pp. 41566-41587, 2020, doi: 10.1109/ACCESS.2020.2976828
- [6] D. Kumar and P. S. Bhowmik, Genetic Algorithm-based Optimal Placement of STATCOM in Pre-islanding and Post-islanding Condition, 2020 *IEEE Calcutta Conference (CALCON)*, Kolkata, India, 2020, pp. 373-377, doi: 10.1109/CALCON49167.2020.9106567
- [7] J. Bikanaria, S. Kumar Sharma, K. Parkh and N. Dhakre, "Optimal tuning of PSS and STATCOM based controllers using differential evolution algorithm, 2017 *Recent Developments in Control, Automation & Power Engineering (RDCAPE)*, Noida, 2017, pp. 421-426, doi: 10.1109/RDCAPE.2017.8358308
- [8] Kamari, and et al., Swarm Intelligence Approach for Angle Stability Improvement of PSS and SVC-Based, *SMIB. J. Electrical engineering and Technology*. 15, pp.1001–1014.2020, <https://doi.org/10.1007/s42835-020-00386-w>
- [9] Y. Liu, X. Xiao, X. Zhang and Y. Wang, Multi-Objective Optimal STATCOM Allocation for Voltage Sag Mitigation, in *IEEE Transactions on Power Delivery*, vol. 35, no. 3, pp. 1410-1422, June 2020, doi: 10.1109/TPWRD.2019.2947715
- [10] M.Y. Suliman and Farrag M. E., Power Balance and Control of Transmission lines using Static Series Compensator, 53rd *International Universities Power Engineering Conference (UPEC)*, pp 1-5, 2018
- [11] Wang C.L. Research on Controlling Measures to Enhance Low Voltage Ride-Through of Wind Farm with DSTATCOM, *North China Electric Power University*, 2015
- [12] Li Wang and Quang-Son Vo, Power Flow Control and Stability Improvement of Connecting an Offshore Wind Farm to a One-Machine Infinite-Bus System using Static Synchronous Series Compensator, *IEEE transactions on Sustainable Energy*, vol. 4, Issue 2, pp 358-369, 2013
- [13] M.T. Alkhayyat and S.M. Bashi, Reduce the Impact of Voltage Sag with Phase Jumping in AC Line Using Unified Power Quality Conditioners UPQC and Open UPQC, 2nd *International conference on electrical, communication, computer, power and control engineering ICECCPCE19*, Mosul, Iraq, 13-14 2nd February, 2019
- [14] T. Stetz, F. Marten, and M. Braun, Improved low voltage grid-integration of photovoltaic systems in Germany, *IEEE Trans. Sustain. Energy*, vol. 4, no. 2, pp. 534-542, 2013
- [15] M.Y. Suliman and S. M. Bashi, Fast response SSSC based on instantaneous power theory, *International Conference on Electrical, Communication, Computer, Power, and Control Engineering (ICECCPCE)*, pp 174-178, 2013
- [16] Ali, A.J., Suliman, M.Y., Khalaf, L.A., Sultan, N.S., "Performance investigation of stand-alone induction generator based on STATCOM for wind power application," *International Journal of Electrical and Computer*, vol. 10 no. 6 pp. 5570-5578. 2020
- [17] V. Ponanathi and B. R. Kumar, Three-phase statcom controller using D-Q frame theory for a three-phase SEIG feeding single phase loads, 2nd *International Conference on Electronics and Communication Systems (ICECS)*, pp 926-931, 2015
- [18] Mohammed Y. Suliman, "Voltage profile enhancement in distribution network using static synchronous compensator STATCOM", *International Journal of Electrical and Computer Engineering*, Vol. 10, No. 4, 2020.
- [19] M. Y. Suliman, M. E. Farrag and S. Bashi, Design of Fast Real Time Controller for the SSSC Based on Takagi-Sugeno (TS) Adaptive Neuro-Fuzzy Control System, *International Conference on Renewable Energies and Power Quality (ICREPQ'14)*, vol 1, no 12, pp 1025-1030, 2014
- [20] V. Ponanathi and B. R. Kumar, Three-phase STATCOM controller using D-Q frame theory for a three-phase SEIG feeding single phase loads, *Electronics and Communication Systems (ICECS)*, 2nd *International Conference IEEE Conf.*, Coimbatore, India, 2015, 26-27 Feb., pp.926-931, 2015
- [21] M. Y. Suliman and S. S. Al-Juboori, Design of Fast Real Time Controller for the Dynamic Voltage Restorer Based on Instantaneous Power Theory, *International Journal of Energy and Power Engineering*, vol 5, no 2, pp. 1-6, 2016
- [22] S. Khuntia, Simulation Study of a SSSC-based Neuro- Fuzzy Controller for Improvement of Transient Stability in a Three-Machine Power System, *IEEE energy tech*, pp 1-6, 2012
- [23] M. Amirian, Mitigating Sub-Synchronous Resonance Using Static Var Compensator (SVC) Enhanced with Adaptive Neuro-Fuzzy Inference Systems (ANFIS) Controller, 27th *Iranian Conference on Electrical Engineering (ICEE)*, pp. 532-538, 2019
- [24] M. Y. Suliman, Active and reactive power flow management in parallel transmission lines using static series compensation (SSC) with energy storage, *International Journal of Electrical and Computer Engineering (IJECE)*, vol 9, no 6, pp 4598-4609, 2019
- [25] M.T. Alkhayyat, M. Y. Suliman, Neuro Fuzzy based SSSC for Active and Reactive Power Control in AC Lines with Reduced Oscillation, *PRZEGLĄD ELEKTROTECHNICZNY*, ISSN 0033-2097, R. 97 NR 3/2021